



**AALBORG UNIVERSITY**  
DENMARK

**Aalborg Universitet**

## **CLIMA 2016 - proceedings of the 12th REHVA World Congress**

Heiselberg, Per Kvols

*Publication date:*  
2016

*Document Version*  
Publisher's PDF, also known as Version of record

[Link to publication from Aalborg University](#)

*Citation for published version (APA):*  
Heiselberg, P. K. (Ed.) (2016). CLIMA 2016 - proceedings of the 12th REHVA World Congress: volume 8. Aalborg: Aalborg University, Department of Civil Engineering.

### **General rights**

Copyright and moral rights for the publications made accessible in the public portal are retained by the authors and/or other copyright owners and it is a condition of accessing publications that users recognise and abide by the legal requirements associated with these rights.

- ? Users may download and print one copy of any publication from the public portal for the purpose of private study or research.
- ? You may not further distribute the material or use it for any profit-making activity or commercial gain
- ? You may freely distribute the URL identifying the publication in the public portal ?

### **Take down policy**

If you believe that this document breaches copyright please contact us at [vbn@aub.aau.dk](mailto:vbn@aub.aau.dk) providing details, and we will remove access to the work immediately and investigate your claim.

# Model based control for an Optimized Dehumidification with air bypass

## - Optimization of the humidity in area without comfort losses -

Philipp Krimmel<sup>1\*</sup>, Nico Goldschmidt<sup>2\*</sup>, Robin Meier<sup>3</sup>, Horst Schulte<sup>4</sup>, Birgit Müller<sup>5</sup>

*\*Hochschule für Technik und Wirtschaft Berlin, Department I,  
Wilhelminenhof Str. 75A, 12459 Berlin, Germany*

[Philipp.Krimmel@htw-berlin.de](mailto:Philipp.Krimmel@htw-berlin.de); [Nico.Goldschmidt@htw-berlin.de](mailto:Nico.Goldschmidt@htw-berlin.de); [Robin.Meier@gmx.net](mailto:Robin.Meier@gmx.net);  
[Horst.Schulte@htw-berlin.de](mailto:Horst.Schulte@htw-berlin.de); [Birgit.Müller@htw-berlin.de](mailto:Birgit.Müller@htw-berlin.de)

\* corresponding author

### Paper

#### Abstract

*The evolving climate change requires a redesign of our energy use. On one hand, the alternative energy resources are researched, on the other hand the energy must be used more efficiently. For the cooling of non-industrial buildings are used about 105 TWh in Europe every year. That corresponds to an energy procurement cost up to 18 billion euros. In order to conserve resources and reduce CO<sub>2</sub> emissions, there is a great potential for optimization of the cooling energy consumption.*

*The aim is to develop a model-based multivariable controller structure for energy saving through optimized dehumidification and cooling of the air for large air conditioning Systems, which is referred to as "Optimized Dehumidification with air bypass". The basis for the control system is a universal analytic-positioned state-space model of a cross counter flow heat exchanger. This model was created by the method of the infinitesimally small heat exchanger segments according to the dissertation of Wolfgang Wiening, in combination with an air bypass for controlled mixture of air.*

*The developed concept allows beside the regulation of the air temperature also the controlled dehumidification of the air, what other classical systems cannot offer. By conditioning the air from point A to point B in a straight connecting line, the requested cooling energy from the chiller is significantly lower. By using the model-based control concept, the outdoor air is no longer undercooled. This reduces strongly the need to warm up again the air after the cooling coil post and brings to the concept a higher energetic advantage. Moreover the new concept guaranteed a better thermal comfort.*

**Keywords – Resource conservation; CO<sub>2</sub> emission reduction; Ventilation; Air conditioning; Model-based Control;**

#### 1. Introduction

The goal of the „Optimized dehumidification with air bypass” technology is to regulate optimally the humid and warm air to a desired state in the hx diagram without comfort losses and with high energy-efficiency. A controlled dehumidification of the air is achieved by the use of minimal cooling energy and the undercooling of the air after the

cooler is avoided. The drying of the air should not be directly together with the cooling, it should be possible to take away the energy from the dissolved water vapor of the (dry) air. There is a strong mutual influence between the water vapor particles and the air particles, a complete separation is not realizable.

Present investigations ([1] and [2]) of different ventilation systems for air cooling show that the conditioning of the air occurs mostly not efficiently, what brings an additional optimization potential for the energy consumption reduction. Ventilation systems can do the air cooling and the air dehumidification, for that they have the following components which are shown at the Figure 1.

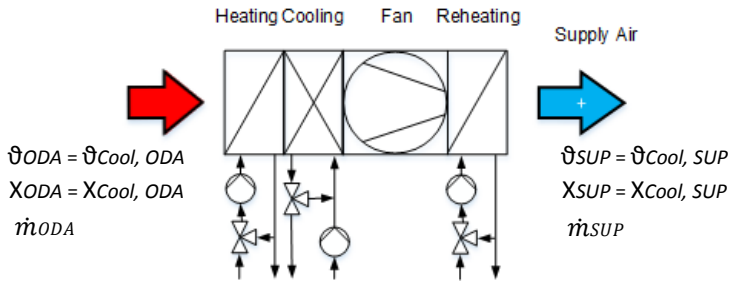

Figure 1: Basic components of a ventilation system with cooling and drying out function

With the technical measuring investigations was found out that the desired air state is only reachable by high energy consumption. For the efficient work of the ventilation systems the characteristic curve (track 1-2-3-4, Figure 2) is energetically unfavorably, because the dehumidification of the air (track 2-3) takes place only when the air is cooled down to the saturation line (track 1-2, Figure 2). Afterwards the dehumidified air must be reheated again up to the desired air temperature (track 3-4, Figure 2), what beside the strong air cooling leads to an additional energy consumption of the whole ventilation system.

The total energy consumption for an air state of 24 °C and with the water vapor of 9,6 g/kg is determined with following energy balance (1):

$$\Delta h_{cool,1} = \Delta h_{1-2} + \Delta h_{2-3} + \Delta h_{3-4} \quad (1)$$

To increase the energy efficiency of the ventilation systems the characteristic curve should be a line (route 1-4, Figure 2). The whole involved energy is calculated like this:

$$\Delta h_{cool,2} = \Delta h_{1-4} \quad (2)$$

$$\Delta h_{cool,2} < \Delta h_{cool,1}$$

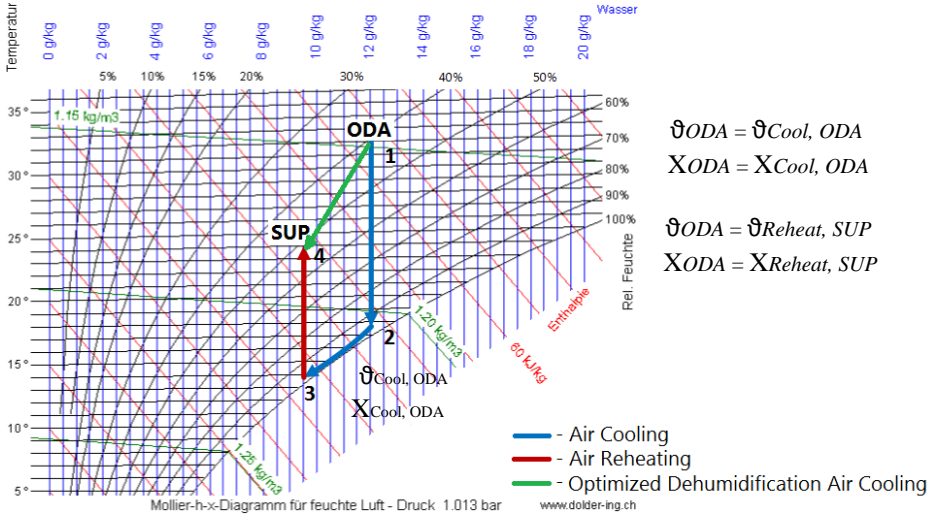

Figure 2: air state change in standard ventilation system

## 2. Concept

The developed concept serves the optimized regulation of the supply air by the admixture of non-treated air via the air bypass ( $\vartheta_{Bypass}$ ,  $X_{Bypass}$ ) with the cooled and if necessary dehumidified air from the chiller ( $\vartheta_{SUP}$ ,  $X_{SUP}$ ) (Figure 3).

With the new technology the outdoor air (ODA) is divided by motorized flaps in a necessary relation with reached the desired air condition after the cooler (Supply Air, SUP). In addition, the water mass stream is adjusted with the help of limiting valve in the hydraulic part of the cooler, so that an optimization of the cooling energy consumption is possible.

By the development of the model-based regulation structure it was made the assumption that the pressure resistance in the air duct with the chiller (3) and the pressure resistance about the air bypass (4) are the same. Only under the condition that the system is hydraulically compensated, the linear distribution of the air mass streams is guaranteed. By a linear change of both air mass streams, it will be possible to reach the optimum regulation and exactly set of the desired mixing air condition (temperature, water vapor).

$$\Delta p_{cooler,duct} = \Delta p_{cooler} + \frac{1}{2} \rho v_{duct}^2 \frac{\lambda l_{duct}}{A_{duct}} \quad (3)$$

$$\Delta p_{bypass,duct} = \frac{1}{2} \rho v_{bypass}^2 \frac{\lambda l_{bypass}}{A_{bypass}} \quad (4)$$

$$\Delta p_{bypass,duct} = \Delta p_{cooler,duct} \quad (5)$$

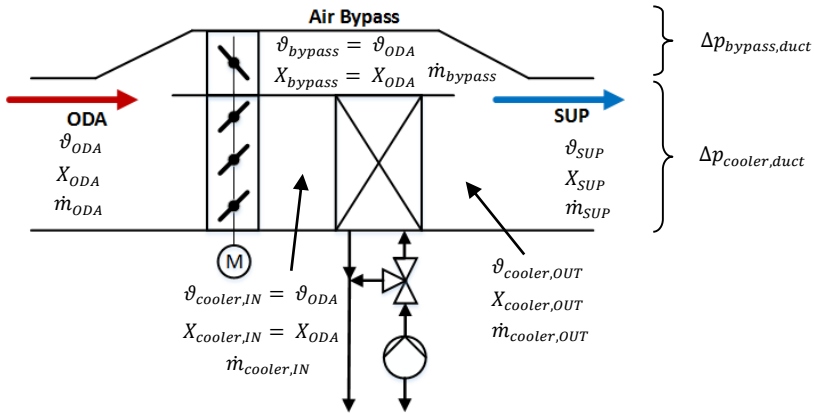

Figure 3: draught of the control system "Optimized Dehumidifikation with air bypass"

The Figure 4 shows the resultant workspace which originates from the admixture in dependence of the flap position and the variable water volume stream which is indicated in the Figure 3.

The following two characteristic curves are the upper and lower border of the workspace, the green line correspond to the open flap and the blue line correspond to the closed flap. In this area, the desired air condition is achieved with an optimized chill energy use. An undercooling of the air is avoided and so the reheating of the air is no longer necessary.

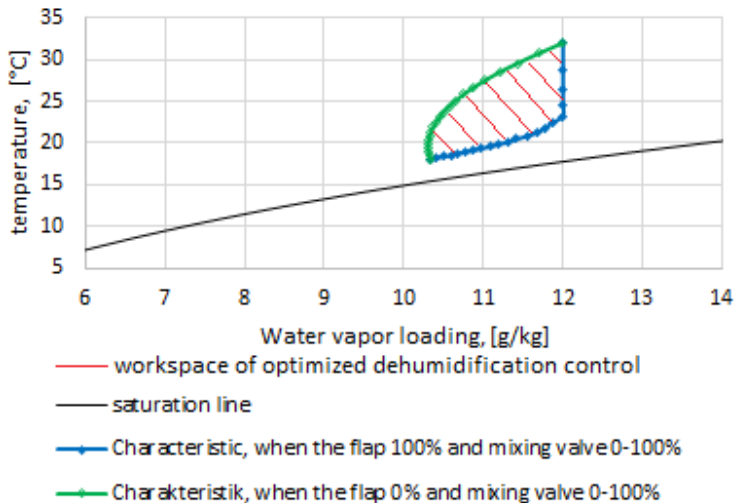

Figure 4: Simulation results of the concept "Optimized dehumidifikation with air bypass"

### 3. Modelling

The basis of the model for the aerial admixture, especially the mix of the air temperatures (6) and the water vapor loadings (7) from the air bypass and the cooler are calculated as followed:

$$\vartheta_{SUP}(\tilde{x}_{2WV}, \tilde{x}_{flap}) = \frac{\vartheta_{cooler,OUT} \dot{m}_{cooler}(\tilde{x}_{flap}) + \vartheta_{bypass} \dot{m}_{bypass}(\tilde{x}_{flap})}{\dot{m}_{cooler}(\tilde{x}_{flap}) + \dot{m}_{bypass}(\tilde{x}_{flap})} \quad (6)$$

$$X_{SUP}(\tilde{x}_{2WV}, \tilde{x}_{flap}) = \frac{X_{cooler,OUT} \dot{m}_{cooler}(\tilde{x}_{flap}) + X_{bypass} \dot{m}_{bypass}(\tilde{x}_{flap})}{\dot{m}_{cooler}(\tilde{x}_{flap}) + \dot{m}_{bypass}(\tilde{x}_{flap})} \quad (7)$$

with

$$\vartheta_{bypass} = \vartheta_{ODA} \quad \text{and} \quad X_{bypass} = X_{ODA}$$

and

$$\dot{m}_{ODA} = \dot{m}_{SUP} = \dot{m}_{cooler}(\tilde{x}_{flap}) + \dot{m}_{bypass}(\tilde{x}_{flap}) \quad (8)$$

Taking into account that the pressure drop across the bypass air corresponds to the pressure loss of the cooling coil, may be given as a first approximation for the mass flows  $\dot{m}_{cooler}$  and  $\dot{m}_{bypass}$ , that

$$\dot{m}_{cooler} = \dot{m}_{ODA} \tilde{x}_{flap} \quad (9)$$

$$\dot{m}_{bypass} = \dot{m}_{ODA} - \dot{m}_{cooler} = \dot{m}_{ODA} (1 - \tilde{x}_{flap}) \quad (10)$$

Also can be assumed that for the two-way valve in the hydraulic circle of the cooling coil in combination with a feed pump applies

$$\dot{m}_{water,IN}(\tilde{x}_{pump}) = \dot{m}_{pump,max} \tilde{x}_{pump} \quad (11)$$

, considering the valve authority corresponds to about  $a_v \approx 0,5$ .

As a basis for the model of the cooler component is a cross-flow finned tube heat exchanger, as displayed in figure 5.

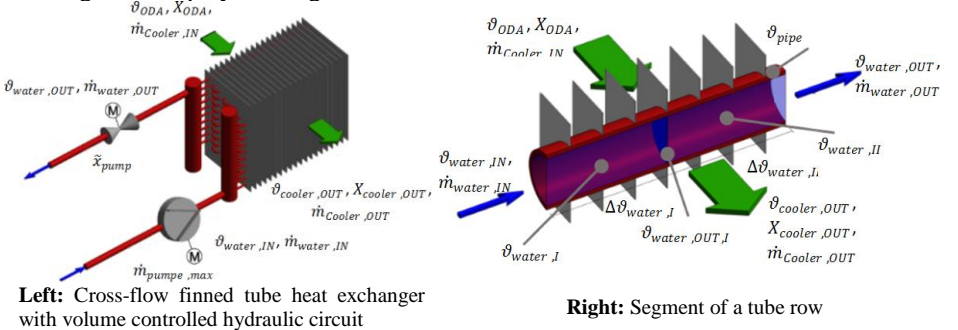

Figure 5: Cross-flow finned tube heat exchanger

As noted in [1], [2], [3] and [4], the thermodynamic is accounted for using an infinite small segment of a heat exchanger. Proceeding the averages is formed by [1] for a segment model, shown in figure 6 on the right side. The equations of motion of a tube row are:

$$\begin{aligned} \dot{\vartheta}_{pipe} = f_1(\tilde{x}_{pump}) & \left[ \frac{1}{2}(\vartheta_{water,II} - \vartheta_{water,I}) - \vartheta_{pipe} \right] + f_2(\tilde{x}_{flap}) [\vartheta_{ODA} - \vartheta_{pipe}] \\ & + f_3(\vartheta_{pipe}, \tilde{x}_{flap}) [X_{ODA} - X_{pipe}(\vartheta_{pipe})] \end{aligned} \quad (12)$$

$$\dot{\vartheta}_{water,I} = f_4(\tilde{x}_{pump}) \left[ \vartheta_{water,IN} - \frac{1}{2}(\vartheta_{water,I} + \vartheta_{water,II}) \right] + f_5(\tilde{x}_{pump}) [\vartheta_{pipe} - \vartheta_{water,I}] \quad (13)$$

$$\dot{\vartheta}_{water,II} = f_4(\tilde{x}_{pump}) [\vartheta_{water,I} - \vartheta_{water,II}] + f_5(\tilde{x}_{pump}) [\vartheta_{pipe} - \vartheta_{water,II}] \quad (14)$$

with

$$\begin{aligned} f_1(\tilde{x}_{pump}) &= \frac{\alpha_W(\dot{m}_{water,IN}(\tilde{x}_{pump})) A_{pipe,IN}}{m_{pipe} c_{pipe}} & f_2(\tilde{x}_{flap}) &= \frac{\alpha_{air}(\dot{m}_{cooler}(\tilde{x}_{flap})) A_{pipe,OUT}}{m_{pipe} c_{pipe}} \\ f_3(\vartheta_{pipe}, \tilde{x}_{flap}) &= \begin{cases} \frac{\beta A_{pipe,OUT} r_{steam}(\vartheta_{pipe}) \psi_{steam}(\dot{m}_{cooler}(\tilde{x}_{flap}))}{c_{pipe} m_{pipe} \kappa_{steam}(\dot{m}_{cooler}(\tilde{x}_{flap}))} & , \vartheta_{pipe} \leq \vartheta_{TP} \\ 0 & , \vartheta_{pipe} > \vartheta_{TP} \end{cases} \\ f_4(\tilde{x}_{pump}) &= \frac{2}{T_{l,water}(\dot{m}_{water,IN}(\tilde{x}_{pump})) \Delta \tilde{x}_{seg}} & f_5(\tilde{x}_{pump}) &= \frac{\alpha_{water}(\dot{m}_{water,IN}(\tilde{x}_{pump})) A_{pipe,IN}}{m_{water} c_{p,water}} \end{aligned}$$

, the enthalpy of vaporization  $r_{steam}$

$$r_{steam}(\vartheta_{pipe}) = \begin{cases} r_0 + c_{p,steam} \vartheta_{pipe} & , X_{pipe}(\vartheta_{pipe}) \neq 0 \\ 0 & , X_{pipe}(\vartheta_{pipe}) = 0 \end{cases} \quad (15)$$

and the water vapor loading of the pipe  $X_{pipe}$

$$X_{pipe}(\vartheta_{pipe}) = \begin{cases} X_0 + m_X \vartheta_{pipe} & , \vartheta_{pipe} \leq \vartheta_{TP} \\ 0 & , \vartheta_{pipe} > \vartheta_{TP} \end{cases} \quad (16)$$

According to [5], the output temperature and the water vapor loading of the cooling air can be calculated with the inlet state of the air  $\vartheta_{ODA}$ ,  $X_{ODA}$  and the surface temperature of the pipe  $\vartheta_{pipe}$ . The equations are

$$\vartheta_{cooler,OUT} = \vartheta_{ODA} e^{-\kappa_{air}(\tilde{x}_{flap})} + \vartheta_{pipe} (1 - e^{-\kappa_{air}(\tilde{x}_{flap})}) \quad (17)$$

$$X_{cooler,OUT} = X_{ODA} e^{-\kappa_{steam}(\tilde{x}_{flap})} + X_{pipe} (1 - e^{-\kappa_{steam}(\tilde{x}_{flap})}) \quad (18)$$

$$\vartheta_{water,OUT} = 1 \frac{1}{2} \vartheta_{water,II} - \frac{1}{2} \vartheta_{water,I} \quad (19)$$

, wherein for the power coefficient of the air  $\kappa_{air}$  and from the vapor  $\kappa_{steam}$  the following relationship applies

$$\kappa_{air}(\tilde{x}_{flap}) = \frac{\alpha_{air}(\tilde{x}_{flap}) A_{air}}{c_{p,air} \dot{m}_{air}} \quad \text{and} \quad \psi_{air} = 1 - e^{-\kappa_{air}(\tilde{x}_{flap})} \quad (20)$$

$$\kappa_{steam}(\tilde{x}_{flap}) = \begin{cases} \frac{\beta(\tilde{x}_{flap}) A_{air}}{\dot{m}_{air}} & , X_{pipe} \neq 0 \\ 0 & , X_{pipe} = 0 \end{cases} \quad \text{and} \quad \psi_{steam} = 1 - e^{-\kappa_{steam}(\tilde{x}_{flap})} \quad (21)$$

By substituting (17), (18), (19) and (11), (9), (10) in (6) and (7) is indicated, the overall system of the cooler component with an air bypass in the form of the state space as follows

$$\dot{\mathbf{x}} = \mathbf{A}(\mathbf{x}, \mathbf{u}, \mathbf{z})\mathbf{x} + \mathbf{B}(\mathbf{x}, \mathbf{u}, \mathbf{z})\mathbf{u} + \mathbf{E}(\mathbf{x}, \mathbf{u}, \mathbf{z})\mathbf{z} \quad (22)$$

$$\mathbf{y} = \mathbf{C}(\mathbf{x}, \mathbf{u}, \mathbf{z})\mathbf{x} + \mathbf{D}(\mathbf{x}, \mathbf{u}, \mathbf{z})\mathbf{u} + \mathbf{F}(\mathbf{x}, \mathbf{u}, \mathbf{z})\mathbf{z} \quad (23)$$

with the special vectors of the state space

$$\mathbf{x} = \begin{pmatrix} \vartheta_{Pipe} \\ \vartheta_{water,I} \\ \vartheta_{water,II} \end{pmatrix} \quad \mathbf{y} = \begin{pmatrix} \vartheta_{SUP} \\ X_{SUP} \\ \vartheta_{water,OUT} \end{pmatrix} \quad \mathbf{z} = \begin{pmatrix} \vartheta_{ODA} \\ X_{ODA} \end{pmatrix} \quad \mathbf{u} = \begin{pmatrix} \tilde{x}_{flap} \\ \tilde{x}_{pump} \end{pmatrix} \quad (24)$$

And the matrices  $\mathbf{A}$ ,  $\mathbf{B}$ ,  $\mathbf{C}$ ,  $\mathbf{D}$ ,  $\mathbf{E}$  and  $\mathbf{F}$ . The structure is shown in the Figure 7.

#### 4. Control

The shown state space model is a Multi-Input- and Multi-Output system with the following Input and Output variables

$$\tilde{\mathbf{u}} = \begin{pmatrix} z_1 \\ z_2 \\ u_1 \\ u_2 \end{pmatrix} = \begin{pmatrix} \vartheta_{ODA} \\ X_{ODA} \\ \tilde{x}_{flap} \\ \tilde{x}_{pump} \end{pmatrix} \quad \text{and} \quad \mathbf{y} = \begin{pmatrix} y_1 \\ y_2 \\ y_3 \end{pmatrix} = \begin{pmatrix} \vartheta_{SUP} \\ X_{SUP} \\ \vartheta_{water,OUT} \end{pmatrix} \quad (25)$$

By the preceding works [1] and [2] on this subject is known that the dimensions  $\vartheta_{Air}$  and  $X_{air}$  are strongly coupled with each other and cannot be decoupled. As a methodical approach was applied the optimally regulation in the form of a Linear-quadratic Regulator (LQR), by the solution of a Riccati equation. In concerns a state regulator



whose return matrix about the minimization of a square costs-/quality function  $J$  can be optimally determined. With the help of [6] and [7] the control law of linear-quadratic regulator with I-component (I-LQR-y) was applied. It is

$$K = [K_y, K_i] = R^{-1}B^T P L C^T (C L C^T)^{-1} \quad (26)$$

By solving from  $P$  with the help of the Ljapunov-equation or the Riccati-equation

$$\begin{aligned} \bar{A}^T P + P \bar{A} &= -\bar{Q} \\ (A - BKC)^T P + P(A - BKC) + C^T K^T R K C + Q &= 0 \end{aligned} \quad (27)$$

Taking into account quality-function  $J$  by minimizing the expectation  $E_{LQR}$

$$J(y, u) = \int_0^\infty (y^T Q y + u^T R u) dt \quad \min_{K} E_{LQR}\{J(x_0, -Ky)\} \quad (28)$$

and the weighting matrices  $Q$  and  $R$

$$Q = \text{diag}(q_{ii}), \quad q_{ii} > 0, \quad i = 1, \dots, r \quad R = \text{diag}(r_{ii}), \quad r_{ii} > 0, \quad i = 1, \dots, m$$

An optimum solution can be solved for the optimum problem. By specific adaptation of the weighting matrices the single variable  $y$  and  $\tilde{u}$  are punished according to her influencing control and it can be carried out a specific prioritization of the regulatory dimensions.

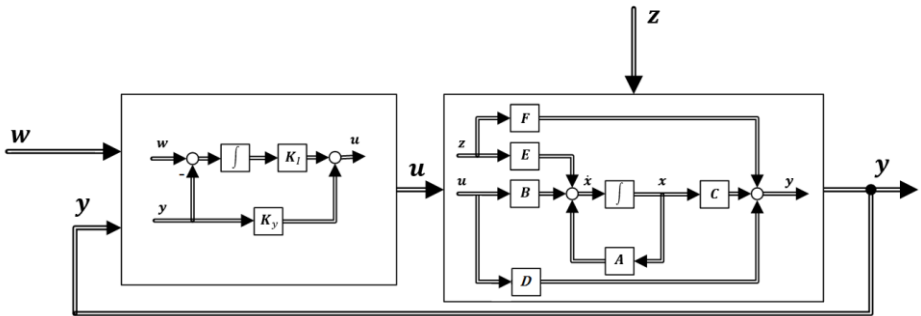

Figure 7: Block diagram of the control structure and the state-space model

## 5. Simulation / Equations

To demonstrate the function of the multivariable controller, a model was created in a simulation environment based on the equations of motion of the cooling coil with air bypass. The aim of the simulation is the stabilization of a defined operating point, which can not only be achieved with the available cooling coil. This and the constant temperature of the cooling water is

$$\mathbf{w} = \begin{pmatrix} \vartheta_{setpoint} \\ X_{setpoint} \end{pmatrix} = \begin{pmatrix} 23 \text{ } ^\circ\text{C} \\ 10,5 \text{ g}_{(w)}/\text{kg}_{(L)} \end{pmatrix} \quad \text{and} \quad \vartheta_{water,IN} = 6^\circ\text{C}$$

$\vartheta_{setpoint}$  - Setpointtemperature after the cooling coil,  $^\circ\text{C}$

$X_{setpoint}$  - Setpoint water vapor,  $\text{g}/\text{kg}$

$\vartheta_{water,IN}$  - Water supply (inlet) temperature for the cooling coil,  $^\circ\text{C}$

The outdoor air conditioning, as well as the maximum mass flow from the water circuit and the air side is defined as

$$\mathbf{z} = \begin{pmatrix} \vartheta_{ODA} \\ X_{ODA} \end{pmatrix} = \begin{pmatrix} 32 \text{ } ^\circ\text{C} \\ 12 \text{ g}_{(w)}/\text{kg}_{(L)} \end{pmatrix} \quad \text{and} \quad \begin{pmatrix} \dot{m}_{ODA} \\ \dot{m}_{pump,max} \end{pmatrix} = \begin{pmatrix} 2700 \text{ m}^3/\text{h} \\ 2,10 \text{ m}^3/\text{h} \end{pmatrix}$$

$\vartheta_{ODA}$  - Outdoor air temperature,  $^\circ\text{C}$

$X_{ODA}$  - Outdoor water vapor,  $\text{g}/\text{kg}$

$\dot{m}_{ODA}$  - Outdoor air mass flow,  $\text{kg}/\text{s}$

$\dot{m}_{pump,max}$  - Water mass flow through the cooling coil,  $\text{kg}/\text{s}$

The following graphs show the simulation results:

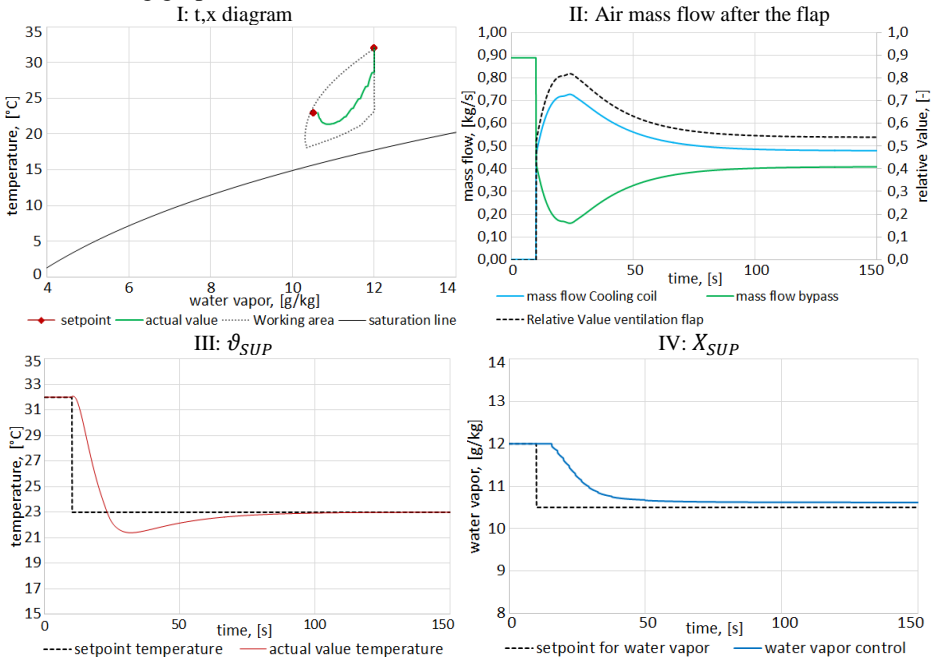

Figure 8: Simulation results

In the upper left corner is the tx diagram of the supply air after the cooler component. It can be seen that the desired operating point is reached. The trajectory may vary and is mainly dependent on the selected weighting matrices  $\mathbf{Q}$  and  $\mathbf{R}$ . The bottom graphs show

the time profiles of the temperature and the water vapor loading, forming the tx diagram. The graph in the upper right corner shows the mass flows through the bypass and the cooling register, as well as the relative size of the flap actuator. The intervention of the multivariable controller based on the generated control parameters is primarily focused on a goal-oriented fast dehumidification. By shifting the parameters the characteristic of the control and the prioritization can be changed.

## 6. Conclusion

For the cooling of non-industrial buildings are required about 105,000 GWh yearly in Europe [8]. Aim is to develop a model-based linear-square regulator structure (LQR with Riccati equation) that make possible an exactly compensate a defined work point to the fulfilment of the comfort without additional reheating of the supply air. By the use of the concept "Optimized dehumidification with air bypass" for demand control of the temperature and the water vapor loading of the supply air the power consumption for the air conditioning can be reduced up to 10 %, obtained on the final energy. This means for Europe a reduction of the electric energy around up to 10,200 GWh and the CO<sub>2</sub> emission around up to 5,946,600 t/a. With an accepted average price for electricity of 0,201 €/kWh in Europe (EU27) this one saving potential corresponds up to 2 milliards €/a.

## 7. Future Work

In the next steps, the controller structure is extended with the gain scheduling method for the entire workspace. A further task is to expand the model. The aim is not to regulate the supply air as before, but the extract air from the room in light of other components of a ventilation system and a defined room volume with sources of heat and humidification.

## References

- [1] C. Ober, Das Verhalten von Kreuzstromwärmeübertragern beim Kühlen und Entfeuchten von Luft, 1978, pp. 93 S., 34 Bild. 8".
- [2] W. Wienen, "Zur Modellbildung, Regelung und Steuerung von Wärmeübertragern zum Heizen und Kühlen von Luft," Aachen, 1986.
- [3] W. Polifke and J. Kopitz, Wärmeübertragung, 2., aktualis. Aufl ed., München [u.a.]: Pearson, 2009, p. 606 S..
- [4] S. Baumgarth, B. Hörner and J. Recker, Handbuch der Klimatechnik, vol. 1., Heidelberg: C.F. Müller Verlag, 2008.
- [5] VDI-Wärmeatlas, 11. bearb. und erw. Aufl ed., Berlin [u.a.]: Springer Vieweg, 2013, p. 1650 S..
- [6] O. Föllinger and F. Dörrscheidt, Regelungstechnik, 10. durchges. Aufl., Nachdr. der 8., überarb. Aufl. 1994 ed., Heidelberg [u.a.]: Hüthig, 2008, pp. XIII, 633 S..
- [7] J. Lunze, Regelungstechnik 2: "Mehrgrößenregelung, Digitale Regelung", Berlin Heidelberg: Springer Verlag, 2010.
- [8] J. Adnot et al., "Energy Efficiency and Certification of Central (EECCAC). Study for the D.G. Transportation-Energy (DGTREN) of the Commission of the E.U., Final report.," ARMINES, Paris, 2003.
- [9] H. Hartmann, "Entwicklung einer Regelung für die hydraulische Schaltung OpDeCoLo," Berlin, 2012.

